

**Computer science**  
**Higher level**  
**Paper 1**

Friday 5 May 2017 (afternoon)

2 hours 10 minutes

---

**Instructions to candidates**

- Do not open this examination paper until instructed to do so.
- Section A: answer all questions.
- Section B: answer all questions.
- The maximum mark for this examination paper is **[100 marks]**.

## Section A

Answer **all** questions.

1. Describe the use of beta testing. [2]
2. Identify **two** causes of data loss. [2]
3. Identify **two** reasons for releasing a software update. [2]
4. Explain why cache memory can speed up the processing within a computer. [2]
5. One of the functions of an operating system is memory management.  
Describe how this function prevents the system from crashing when more than one program is run at the same time. [2]
6. Identify any **two** of the layers of the OSI model. [2]
7. Explain how compression of data may lead to negative consequences. [3]
8. Explain how the use of media access control (MAC) addresses can improve security. [3]
9. Identify the components of a node in a doubly linked list. [3]
10. Outline the reason why recursive solutions can be memory intensive. [2]
11. Identify **two** features of an autonomous agent acting within a larger system. [2]

### Section B

Answer **all** questions.

**12.** A large company has taken over another business. This takeover has required various changes to be made. One of the changes requires data migration.

- (a) (i) Define the term *data migration*. [1]
- (ii) Describe **two** problems, concerning data migration, which the company may have to overcome. [4]
- (b) Other than data migration, describe **two** aspects of change management that may arise from this takeover. [4]

The company produces industrial chemicals. One of the chemical processes is represented by the following logic diagram.

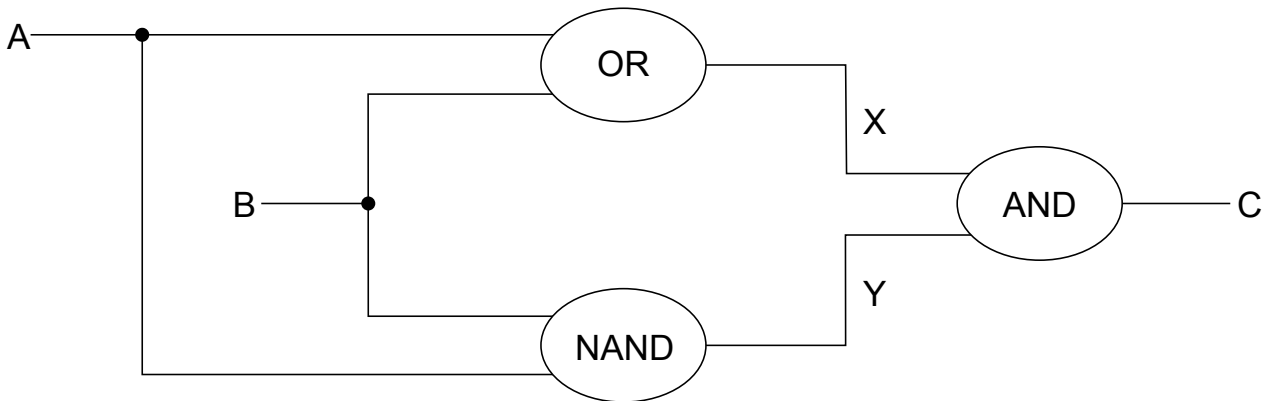

- (c) (i) Construct the truth table corresponding to this diagram. [3]
- (ii) Identify the single logic gate that is equivalent to this diagram. [1]
- (d) Outline how truth tables can be used to test that any two logic diagrams are equivalent. [2]

Turn over

13. (a) By **copying** the table below, trace the following algorithm using the data in the collection DATA. **Note:** B and C are also collections and are initially empty.

```

DATA = {2,4,-1,3}
loop while DATA.hasNext()
  A = DATA.getNext()
  if A >= 0 then
    if A mod 2 = 0 then
      B.addItem(A)
    else
      C.addItem(A)
    end if
  end if
end loop

```

DATA.hasNext() ?	A	A >= 0?	A mod 2 = 0?	Contents of B	Contents of C

[3]

- (b) Outline the steps involved in performing a binary search on an array of ascending numbers. **Note:** you can assume that the search value is present in the array and that initially `LOW` is the index of the first value in the array and `HI` is the index of the last value.

[4]

- (c) A collection called `NUMBERS` is to be searched to see if it contains a specified value. Construct an algorithm in pseudocode to perform the following:
- input the number, `S`, to be searched for
  - read in the values from the `NUMBERS` collection into the array `D`. **Note:** you can assume that the array is large enough and that the collection is **not** empty
  - perform a linear search for `S` on the array `D`
  - output the message “found” or “not found” as appropriate.

[5]

A binary search can be performed on the array `D`, if the values in `D` are in ascending order. As the values are being read from `NUMBERS` into `D` they are checked to see if they are in order.

- (d) Without writing pseudocode, suggest how this check could be performed.

[3]

14. A laptop computer supplements its primary memory by making use of virtual memory.

- (a) Outline the use of paging in relation to virtual memory. [2]

The laptop has 1GB of random access memory (RAM) and a single processor. The laptop is using one of the latest operating systems to run multimedia gaming programs.

- (b) Explain the limitations and consequences of using the laptop for this purpose. [3]

One of the laptop's game applications stores the data relating to the different actions of one of its characters in a stack.

- (c) Suggest **one** reason why the character's actions might be stored in a stack. [2]

At specific moments during the game this data is read from the stack (S) into a queue (Q).

- (d) Using appropriate access methods for stacks and queues, construct an algorithm that reads the data from the stack and enters it into the queue. You should assume that the queue structure exists and that both structures are of a fixed size. [6]

- (e) Outline **one** advantage of making the queue dynamic. [2]

15. The collection WEATHER contains the temperatures that have been measured for one city over the course of **one week**, starting on Monday and ending on Sunday. Each day, 24 readings were taken, one each hour, the first being at 00:00, the second at 01:00 and so on. The data is stored in chronological order with the data for Monday stored in the collection first, followed by Tuesday and so on.

- (a) State the total number of readings that were taken during this week. [1]

- (b) Construct the algorithm to read this data into a 2D array, A, that would allow the temperature on a specific day at a specific time to be accessed directly. [4]

- (c) Construct the algorithm that will output the day, as a word (for example Tuesday), on which the highest temperature was recorded. [6]

The process described at the start of question 15 is extended so that each week the value and date of the highest temperature recorded that week are stored chronologically in a collection, HIGHEST.

At any point in time, the data from the HIGHEST collection can be read into a suitable data structure that will allow the details of the highest temperatures recorded to be output in descending order. The structure is chosen in order to minimize processing.

- (d) Explain how a suitable data structure can be constructed and used for this purpose. [4]

Turn over

16. An embedded system is used to control the speed of an electric motor.

- (a) With reference to the example, above, define an embedded system. [2]

The diagram shows the main components in a typical negative feedback system.

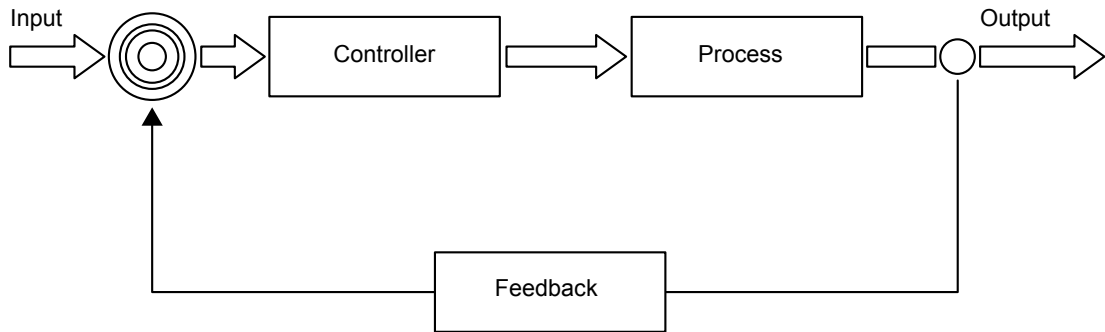

The control system for the electric motor consists of a negative feedback loop.

- (b) Outline the desired outcome of any feedback system. [2]
- (c) List the steps involved in the feedback system for the electric motor. You should make use of the appropriate technical terms of the control system process. [6]

A more complex control system is used to monitor and control the functioning of a power station. This includes a dedicated operating system with sensors and output transducers (actuators) placed at various places around the power station.

- (d) Explain the interaction between the components identified above, if interrupts are generated by the sensors. [5]